

[CONTRIBUTION FROM THE DEPARTMENT OF CHEMISTRY, MASSACHUSETTS INSTITUTE OF TECHNOLOGY]

The Equilibrium of  $\alpha$ -Silver-Cadmium Alloys with Cadmium Vapor<sup>1</sup>

BY GEORGE SCATCHARD AND RICHARD H. BOYD

RECEIVED MARCH 23, 1956

An electronic spectrophotometer is described for measuring the concentration of metal vapor in equilibrium with a solid or liquid alloy. Measurements are reported of the vapor pressures of eight  $\alpha$ -silver-cadmium alloys from 5 to 37 atom % cadmium and from about 0.02 to 0.3 mm. pressure. For each alloy the enthalpy and entropy of evaporation appear to be independent of the temperature. The enthalpy and excess entropy of mixing may each be expressed by a two parameter equation in the mole fraction. A comparison is made of the behavior of the three  $\alpha$ -alloys: copper-zinc, silver-zinc and silver-cadmium.

The determination of the concentration of metal vapor by a photographic comparison of the absorption of a resonance line with that of another line not associated with the ground state was used by Herbenar, Siebert and Duffendack<sup>2</sup> to study the equilibrium of zinc vapor with  $\alpha$ -brass and by Scatchard and Westlund<sup>3</sup> to study the equilibrium of zinc vapor with  $\alpha$ -silver-zinc alloy.

For the study of the equilibrium of cadmium vapor with  $\alpha$ -silver-cadmium alloys we have replaced the photographic plate by an electronic photometer system. Since we were unable to construct a sufficiently stable high pressure cadmium arc, we used a hollow cathode as light source. The absorption of the cadmium resonance line from this very sharp source is about a thousand times as great as from a high pressure source.<sup>4</sup> Thus, the measurements were carried out at lower temperatures. Measurements were made with eight alloys in the approximate range of 0.02–0.3 mm., which corresponds to 725–875°K. for the 5.51% alloy to 620–700°K. for the 37.09% alloy.

**Materials.**—The alloys were prepared from "spectroscopically pure" cadmium from the American Smelting Company and "better than 99.95% pure" silver from the Handy and Harmon Company by adding solid cadmium to molten silver in a graphite crucible in an induction furnace. The alloys were then sealed in evacuated Pyrex tubes and annealed for five days at 500°. Their compositions were determined by gravimetric silver analyses.

**Apparatus.**—The cell is like that of Scatchard and Westlund<sup>3</sup> except that the light path is 1 mm. instead of 10. The furnace and thermo-regulator are the same except that the Chromel-Alumel thermocouples are replaced by platinum-platinum-rhodium couples. The plate-holder of the Hilger E-498 medium quartz spectrograph is replaced by a frame with a sliding plate which carries a slit and a photomultiplier tube. The slit is tilted at 30° from the plate and 30° from the normal to the light beam, which is the minimum angle possible. The sliding plate has bevelled edges and slides between machined guides. Its position is adjusted by a micrometer with No. 40 threads and 25 divisions on its knob. The photomultiplier tube may be moved slightly relative to the slit to center it on the light beam. This exit slit assembly is illustrated in Fig. 1. The assembly is covered with a light-tight metal cover, which also acts as an electrostatic shield. The entrance slit width is 25  $\mu$ , the exit-slit width is 50  $\mu$ .

The light source is pictured in Fig. 2. It is a kovar cup with about 0.1 g. of cadmium electroplated on its surface

according to the directions of Field and Weill.<sup>5</sup> It was prepared for use by evacuating to  $10^{-3}$  mm. and filling with argon to about 1 mm. pressure, which gives optimum uniformity of the arc. The arc is started by means of a spark

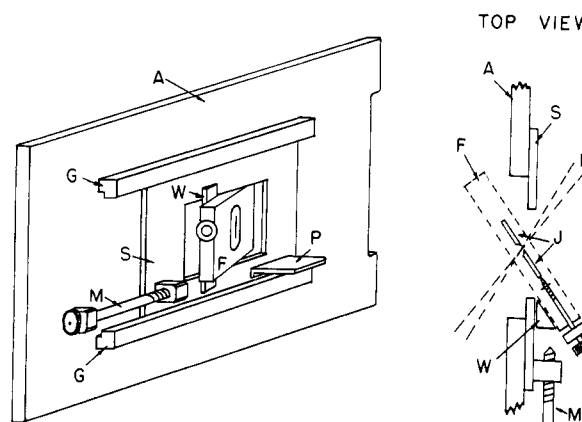

Fig. 1.—Exit slit assembly: A, adaptor plate; F, slit frame; G, guide; M, micrometer screw; P, photomultiplier holder; S, sliding plate; W, wedge.

coil. The tube was operated for several minutes and then re-evacuated. This was repeated several times to remove adsorbed gaseous impurities before the tube was finally refilled and sealed off. The tube is operated at 235 volts and 150 ma. The cathode is kept below room temperature by the cooling water but the glass around the plasma portion of the tube becomes uncomfortably warm to touch. The 2 mm. Pyrex window has a transmission for the cadmium resonance line (3261 Å.) of about 65%.

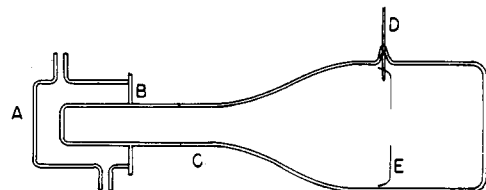

Fig. 2.—Hollow cathode discharge tube: A, brass cooling jacket; B, kovar ring; C, kovar cup; D, tungsten electrode; E, aluminum disc; F, Pyrex window.

Figure 3 is a diagram of the optical system. The lenses are of quartz with a focal length of 25 cm. The mirrors are good quality first-surface-aluminized mirrors purchased from the Edmund Scientific Company of Barrington, New Jersey. Mirror number five has a hole rubbed in the aluminum coating large enough to allow the light to cover the entrance slit. A filter of half-inch plate glass in front of the reference phototube prevents variation of the resonance line intensity from changing the reference beam intensity.

(5) S. Field and A. D. Weill, "Electroplating," Pitman Publishing Co., London, 1935.

(1) Adapted from the Ph.D. Thesis of Richard H. Boyd, M.I.T., 1955. The spectroscopic work was carried out in the Spectroscopy Laboratory at M.I.T. This work received financial support from the United States Atomic Energy Commission, Contract No. AT [30-1]-1002.

(2) A. Herbenar, C. A. Siebert and O. S. Duffendack, *J. Metals*, **188**, 383 (1950).

(3) G. Scatchard and R. A. Westlund, Jr., *THIS JOURNAL*, **75**, 4189 (1953).

(4) For the zinc resonance line the ratio is a little over a hundred.

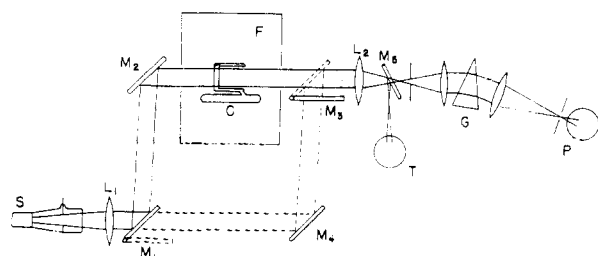

Fig. 3.—Optical system: C, absorption cell; F, furnace; G, spectrograph; L, lens; M, mirrors; P, photomultiplier; S, light source; T, phototube.

The photomultiplier tube is connected across the full resistance,  $R$ , of a Kelvin-Varley slide bridge, and the reference phototube opposes it across a variable fraction of the resistance,  $xR$ . At the null point  $iR - ixR = 0$  or  $i/i_r = x$ . The resistance  $R$  is made up of eleven 0.1 meg. carbon resistors made by the International Resistance Company, any successive pair of which may be shunted by a 0.2 meg. wire wound potentiometer (model number 471) made by the General Radio Company by means of a 10 gang double circuit switch as suggested by Kessler and Wolfe.<sup>6</sup> The d.c. component of the "dark current" is balanced out by a battery placed across a variable resistance in series with the bridge. The fluctuating dark current or dark current noise is minimized by converting the d.c. voltage difference to 60 cycle a.c. by a model 3-8881 synchronous chopper converter of Leeds and Northrup.

The signal is fed to the grid of a preamplifier tube, and its output is fed into the input of a General Radio type 707-A null detector. The signal is amplified by a high gain amplifier sharply tuned at 60 cycles and put across the vertical plates of a cathode ray tube. A 60 cycle signal from the power line is placed on the horizontal plates. The resultant ellipse reduces to a horizontal line at the null point. The amplifier has a gain of 80 db. and a selectivity of 40 db. against the second harmonic. The major component of the signal is 60 cycles and amplified. Fluctuations in the intensity of the source and dark current noise appear as sums and differences from 60 cycles and are not amplified except for the small fraction of their frequency spectrum which lies in a narrow band at 120 cycles.

The photomultiplier tube is operated at about 800 volts, or 80 volts per dynode, from a 600-1000 volt regulated power supply like that of Kessler and Wolfe.<sup>6</sup> The 929 phototube is operated at 100 volts from a tap of the preamplifier power supply. Both the high voltage and  $B^+$  supplies operate from a Sorenson 500 s line voltage regulator.

**Measurements.**—When mirrors 1 and 3 are in the positions shown by the full lines in Fig. 2, the light beam follows the course of the full lines through the cell.

The intensity of the resonance line falling on the photomultiplier,  $I$ , is proportional to the current,  $i$ , and the intensity of the reference beam,  $I_r$ , is proportional to the current  $i_r$ , so

$$I/I_r = \alpha i / \alpha_r i_r = \alpha x / \alpha_r \quad (1)$$

When mirrors 1 and 3 are in the positions shown by the dotted lines, the light beam follows the dotted lines around the cell, and

$$I'_0 / I'_{r0} = \alpha i' / \alpha_r i'_{r0} = \alpha x'_0 / \alpha_r \quad (2)$$

Dividing (1) by (2) gives

$$I/I'_0 = (x/x'_0)(I_r/I'_{r0}) \quad (3)$$

To eliminate the effect of slow changes, such as changes in  $\alpha_r$  due to fatigue in the phototube or changes in  $I_r$ , the measurements were always taken as the set  $x_0, x, x_0, x, x_0$ . The first value of  $x$  was used with the mean of the first two values of  $x_0$ , the second value of  $x$  with the mean of the last two values of  $x_0$ . The light path around the cell is not exactly the same as that through the cell with no vapor in it. At the beginning of each run we made a series of measurements at room temperature to give

$$I_0/I'_0 = (x_0/x'_0)(I_r/I'_{r0}) \quad (4)$$

(6) O. Kessler and R. Wolfe, *J. Opt. Soc. Am.*, **37**, 133 (1947).

Dividing (3) by (4) gives the desired relation

$$I/I_0 = (x/x'_0)/(x_0/x'_0) \quad (5)$$

**Calibration.**—To calibrate the relation between  $I/I_0$  and pressure we assumed that saturated cadmium vapor is a perfect gas, so that  $c = p/RT$ , and used the vapor pressure measurements of Kelley<sup>7</sup> for cadmium. Since the absorption coefficient was found to depend greatly upon the nature of excitation of the resonance line, there was a danger that the calibration curve might change with time, perhaps because of decrease in the pressure of argon. A calibration curve over the region of interest, which lies both sides of the melting point of cadmium, was therefore measured at the beginning of our experiments, another half way through, and a third at the end. Each calibration gave the same curve with ascending or descending temperature, and there is no difference between the last two calibrations. The first run does differ from the others as can be seen in Fig. 4. It was used for the two alloys measured first, and the average of the last two calibrations was used for the others.

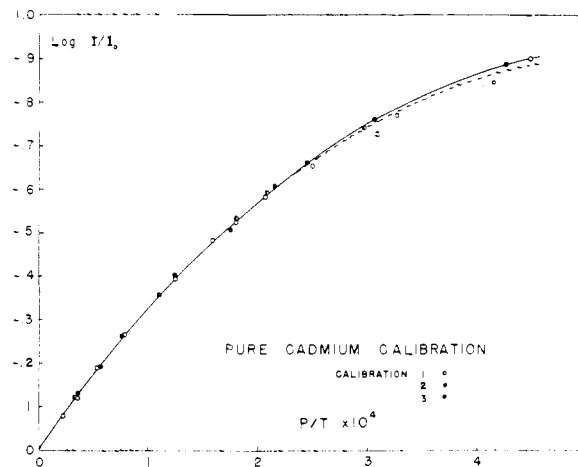

Fig. 4.—Calibration curve.

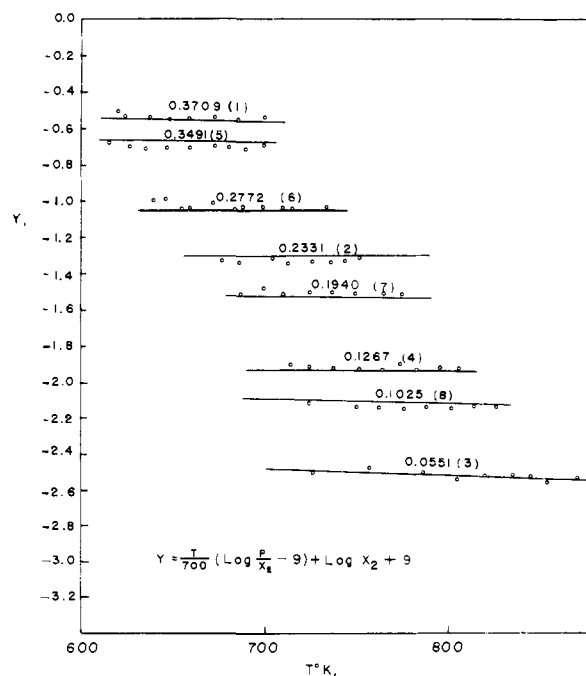

Fig. 5.—Experimental measurements of  $\alpha$ -silver(1)-cadmium(2) alloys.

(7) K. K. Kelley, Bureau of Mines Bull. 385, 1935.

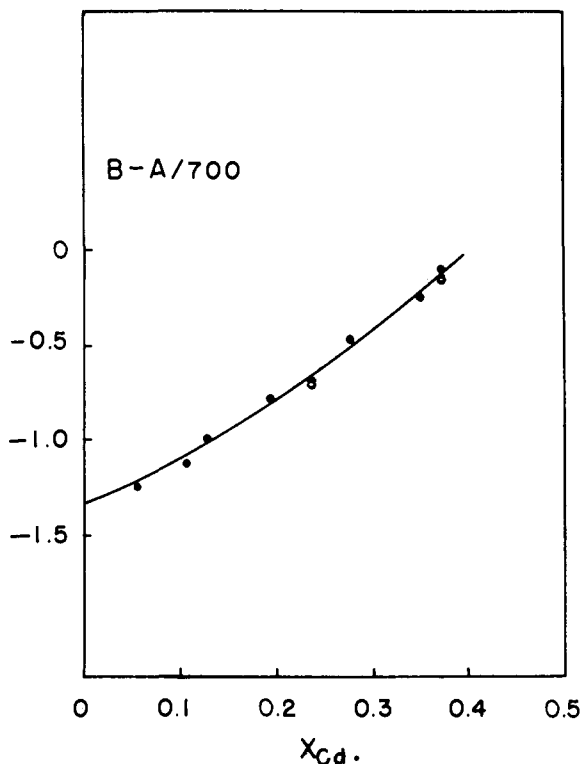

Fig. 6.—Excess free energy term at 700°K. for  $\alpha$ -silver-cadmium alloys.

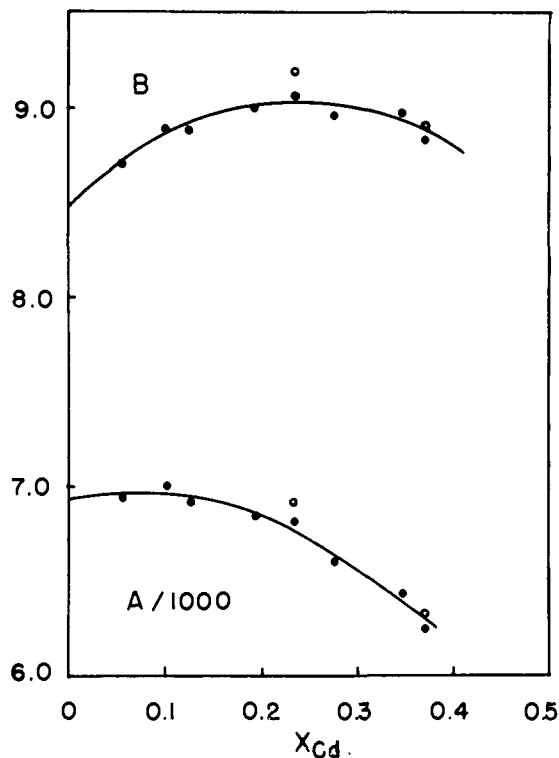

Fig. 7.—Entropy and enthalpy smoothing parameters for  $\alpha$ -silver-cadmium alloys.

Figure 4 shows large deviations either from Beer's law, that  $\log I/I_0 = kc$ , or from the perfect gas law, that  $c = p/RT$ , since the two together would give a straight line. If the non-linearity arises from deviations from the perfect gas law, a pair of molecules must interact so strongly that they no longer absorb the resonance line, and the pair may well be treated as a dimer. Then the absorption measures the concentration of monomer and, therefore, the activity of cadmium, but the calibration is in error because the pressure-temperature ratio is proportional to the total molecular concentration of monomer and dimer, and the relation to the monomer concentration varies with the temperature. We may accept the approximation that the enthalpy of dimerization is constant and determine the dimerization constant as  $\log K_p = 6.608 - 3670/T$ . We believe that a dimerization constant which increases with increasing temperature is so highly improbable that we have assumed that association has no appreciable effect on the non-linearity.

Simple theory of light emission and absorption indicates that the Doppler line broadening is very much greater than the pressure broadening at the temperatures and pressures at which we operate and that for very sharp lines the Doppler broadening should lead to deviations such as we find. The temperature of the cathode is about 300°K., but the temperature of the emitting vapor is somewhat greater, and for pure cadmium the average temperature of the absorbing vapor is 600°K. For 350 and 600° there should be deviations from Beer's law of the form we find, but only about a third as great. The discrepancy may arise from the fact that the velocity distribution in the emitting vapor is probably far from Maxwellian. The same theory indicates that the absorption should increase slightly with the temperature of the absorbing gas, and this effect should reduce the vapor pressures of all our alloys about 2%, but should not change the relations between the alloys appreciably. We have not considered that the theory is certain enough to warrant making any corrections. The theory also gives a factor of the order of 0.01 between the absorption of a very broad band, such as that from a high pressure arc, and that from a narrow band, as from the hollow cathode. None of the calculations are certain enough to warrant publication.

**Measurements with Alloys.**—When the cell containing an alloy was sealed from the vacuum line, the arm containing

the alloy was wrapped with asbestos tape which was saturated with nitrogen in order to reduce the loss of cadmium vapor. During the absorption measurements the alloy was held at each temperature for two hours, rather than for a half hour as with pure cadmium, to allow for the attainment of equilibrium. Otherwise, the measurements were carried out as with pure cadmium. Results from measurements with ascending and with descending temperature fell on the same curve, indicating that equilibrium was attained.

### Results

For each alloy the vapor pressure was expressed by a relation

$$\log p/x_2 = B - A/T \quad (6)$$

The results for all the alloys were expressed as functions of the composition by the relations

$$B = 7.288 + x_1^2[3.075 + 1.885(3 - 4x_1)] \quad (7)$$

$$A = 3,978 + x_1^2[4,894 + 1,990(3 - 4x_1)] \quad (8)$$

The coefficients were obtained by least squaring  $B$  and  $(B - A/700)$ . To compare with the individual experimental measurements we have plotted in Fig. 5.

$$Y = (T/700)(\log p/x_2 - 9) + \log x_2 + 9 = (BT - A)/700 + \log x_2 + 9(1 - T/700) \quad (9)$$

The  $\log x_2$  term gives much the same spread at 700°K. as if  $\log P$  were plotted; the last term serves to reduce the slopes nearly to zero so that they may be more readily compared. The circles correspond to the individual measurements and the lines to equations 6, 7 and 8, smoothing for both temperature and composition. Each curve is labelled with the mole fraction of cadmium and the numbers in parentheses give the order of the measurements. The figure also shows the temperature range of the measurements on each alloy.

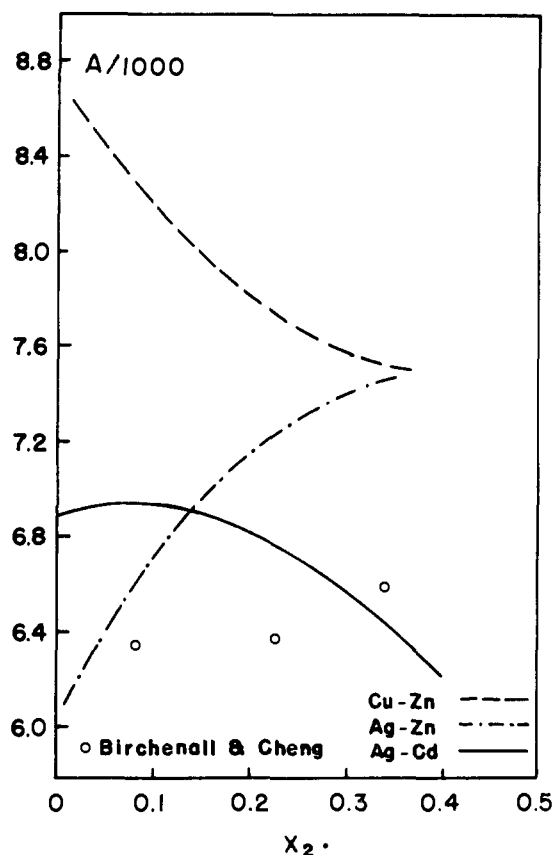

Fig. 8.—Enthalpy parameters for  $\alpha$ -copper-zinc,  $\alpha$ -silver-zinc;  $\alpha$ -silver-cadmium.

Figures 6 and 7 show the values of  $B - A/700$ ,  $B$ , and  $A/1000$  plotted against the mole fraction of cadmium. The filled circles are the values obtained for the individual alloys, and the open circles are the values which would have been obtained from the first two measurements with the calibration curve used for the others. The lines are the values from equations 7 and 8. Figures 5, 6 and 7 show that these equations are sufficient to represent our measurements without additional terms. They extrapolate to a value for the vapor pressure of pure face-centered cubic cadmium about thirty times that of the stable, hexagonal or liquid, cadmium. These values correspond to cadmium vapor at 1 mm. pressure as the standard state. They may be changed to vapor at one atmosphere, to hexagonal crystalline cadmium, to liquid cadmium as standard state or to an infinitely dilute solution in silver as reference state, in the way used for zinc.<sup>3</sup>

#### Discussion

We now have available for comparison vapor-solid equilibrium studies of three alloys of a bivalent metal which crystallizes in the hexagonal form dissolved in a univalent metal which, like the  $\alpha$ -alloys, crystallizes in the face-centered cubic form:  $\alpha$ -copper-zinc,<sup>2</sup>  $\alpha$ -silver-zinc,<sup>3,8</sup> and  $\alpha$ -silver-cadmium. The values of  $A$  and of  $B$  for these three systems are shown in Figs. 8 and 9. The circles are calculated from the measurements of

(8) C. E. Birchenall and C. H. Cheng, *J. Metals*, **187**, 428 (1949).

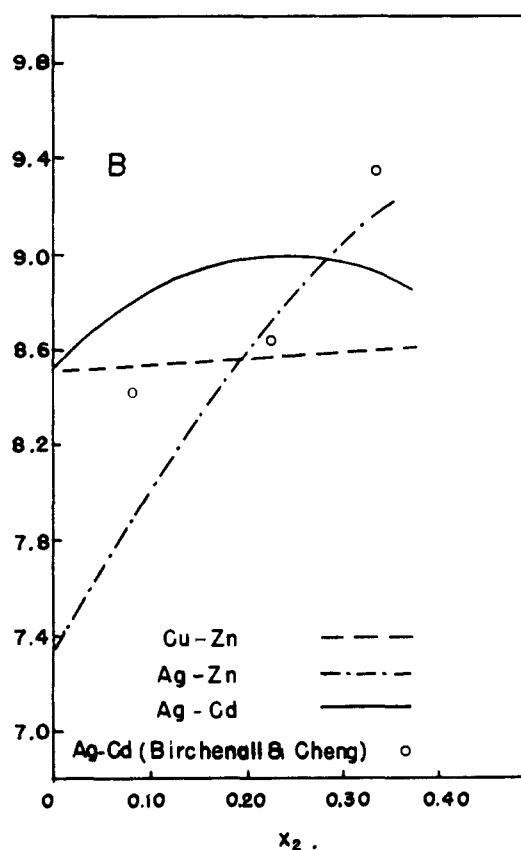

Fig. 9.—Entropy parameters for  $\alpha$ -copper-zinc;  $\alpha$ -silver-zinc;  $\alpha$ -silver-cadmium.

Birchenall and Cheng<sup>8</sup> on three silver-cadmium alloys. The agreement with our results is not nearly as good as for the silver-zinc system.

The silver-cadmium system behaves more like copper-zinc than silver-zinc. The enthalpy of evaporation,  $2.3RA$ , is larger at zero concentration and decreases with the concentration rather than increasing. The great difference, however, is in the excess entropy of evaporation to gas at 1 mm. pressure,  $2.3RB$ , which at infinite dilution for silver-cadmium is the same as for copper-zinc. The variation with composition is greater, but not nearly as great as for zinc-silver, which also has a much smaller value at zero concentration.

The obvious property with which to correlate this behavior is with the relative sizes of the atoms. Pauling<sup>9</sup> gives the radii in ångströms as: copper, 1.28; zinc, 1.38; silver, 1.44; and cadmium, 1.54. The hexagonal structures of zinc and cadmium are not closest packing, however, so these radii are somewhat uncertain. Comparison of the lattice

	0 At. %	25 At. %
Cu-Zn <sup>10</sup>	3.61	3.66
Ag-Zn <sup>11,12</sup>	4.08	4.04
Ag-Cd <sup>11</sup>	4.08	4.13

(9) L. Pauling, *THIS JOURNAL*, **69**, 542 (1947).

(10) E. A. Owen and L. Pickup, *Proc. Roy. Soc. (London)*, **A137**, 397 (1932).

(11) W. Hume-Rothery, G. F. Lewin and P. W. Reynolds, *ibid.*, **A157**, 167 (1936).

(12) H. Lipson, N. J. Petch and D. Stockdale, *J. Inst. Metals*, **67**, 79 (1941).

parameters for pure copper or silver and parameters interpolated for the 25% alloys shows the same relations.

The parameters, in ångströms, are tabulated. Zinc shrinks the silver lattice, but it expands the

copper lattice as cadmium does the silver lattice. We reserve further discussion until after the study of ternary silver-zinc-cadmium alloys.

We are grateful to Mr. T. P. Lin for assistance.

CAMBRIDGE, MASSACHUSETTS

[CONTRIBUTION FROM THE CHEMICAL LABORATORY OF NORTHWESTERN UNIVERSITY]

## The Mechanism of Chemisorption: Hydrogen on Nickel. I

By P. W. SELWOOD

RECEIVED MARCH 9, 1956

Apparatus is described for simultaneous measurement of gas adsorption, and of change of specific magnetization, such as occurs when hydrogen is chemisorbed on a nickel catalyst. The apparatus is readily adapted to automatic recording. Some results are given on the direction of electron transfer during adsorption. Magnetization-volume isotherms are given for the nickel-hydrogen system under various adsorption conditions, and certain transitory phenomena are shown to occur when hydrogen is admitted to a nickel surface.

### Introduction

The purpose of this work was to develop a method for simultaneous measurement of gas adsorption and specific magnetization.<sup>1</sup> Such a method is required for effective use, in the study of chemisorption, of the effect previously described.<sup>2</sup> The effect is, in brief, a change in specific magnetization which is observed when catalytically active nickel takes part in chemisorption. In earlier work, with use of the Faraday method, it was possible to observe and describe the effect but, owing to the large dead-space, it was not possible to make accurate, simultaneous measurements of the gas volumes adsorbed. Apparatus with which this may be done, and some results on the nickel-hydrogen system, are described in this paper.

### Experimental

**Magnetization-Adsorption Apparatus.**—The apparatus consists of standard, volumetric, gas adsorption equipment including purification train, gas buret, manometer, sample tube, McLeod gage, traps and high vacuum pumps. The magnetization assembly includes a primary solenoid of 3100 turns of No. 15 insulated copper wire wound on a brass core 7.6 cm. in internal diameter and 20 cm. long. The solenoid is placed so that the sample is at its center. The sample may consist of 5 to 10 g. of pelleted nickel catalyst sealed in Pyrex or silica to the adsorption apparatus. The primary solenoid carries about 1 ampere stabilized 230 volts a.c., through a variable transformer and ammeter.

The sample tube is compactly surrounded by a secondary coil of 50 turns wound in a single layer either directly on the sample tube or on a thin-walled brass or stainless steel core. The secondary is about 1.4 cm. in diameter and 3.4 cm. long. The wire may be No. 22 insulated copper, or nichrome with oxidized surface (for insulation) depending on the temperature range over which the apparatus is to be used. The secondary is connected in opposition to an identical blank secondary and the difference in e.m.f. produced by these two coils is observed on a vacuum tube voltmeter having a maximum full scale sensitivity of 1 millivolt. The two secondaries are mounted side by side with their centers about 3 cm. apart. While this arrangement produces some mutual inductance between the coils, it has proved to be satisfactory and convenient. The secondaries may be left in position up to about 350°.

For many purposes the secondary e.m.f. may be read directly. A typical nickel-silica catalyst weighing 8 g. and containing 50% of reduced nickel will, after thorough

evacuation, show a loss of magnetization corresponding to about 0.5 millivolt on the meter when hydrogen is admitted to the sample. The apparatus lends itself readily to automatic recording. For this purpose leads are taken from the amplifier output of the voltmeter. The output is passed through a small 1:1 isolating transformer and an instrument rectifier to a rapid acting recorder. The recording feature is especially useful in the study of transitory phenomena. The sensitivity of the apparatus may be improved by placing a sample of reduced catalyst, sealed *in vacuo*, in the opposing secondary. The apparatus then gives essentially a differential method of operation. Some further improvement may be achieved by shifting the zero of the recorder by impressing a small reverse e.m.f. on the recorder input. Arrangement of the apparatus is shown in Fig. 1.

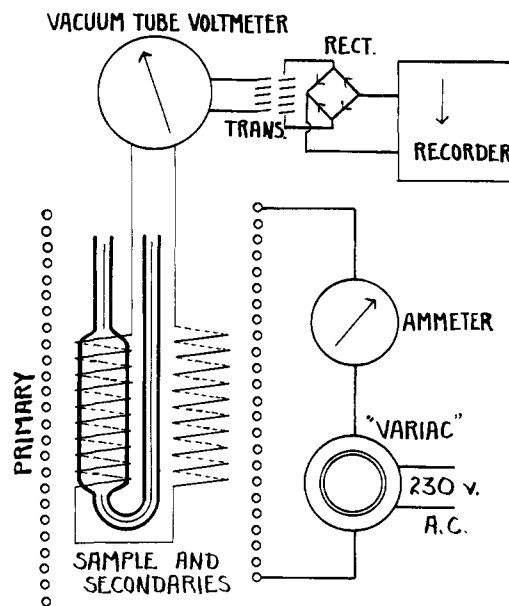

Fig. 1.—Induction apparatus for measuring magnetization.

Various temperatures for reduction, heat treatment or measurement may be obtained with a sleeve heater, or a Dewar flask, as the case may be. These slip into the core of the primary and around the sample and secondaries. The apparatus is arranged so that either the primary or the heater (or the Dewar) may be removed together or separately without disturbing the sample.

Calibration of the apparatus may be done by progressive reduction *in situ* of a mechanical mixture of nickel oxide and alumina. The apparatus lends itself readily to the study of rates of oxidation or reduction, but most use comes from the

(1) A brief communication concerning the method appeared in *THIS JOURNAL*, **78**, 249 (1956).

(2) This is our fourth paper on the effect. The third by Louise E. Moore and P. W. Selwood appeared in *ibid.*, **78**, 697 (1956).